

# HAND BOOK

ON EHV OVERHEAD LINE  
AND UNDERGROUND  
CABLE PROTECTIVE  
REGULATIONS



**Fourth Edition 2024**

---

Issued by:  
Transmission Lines Maintenance & Commissioning Department  
Transmission Power Division  
Dubai Electricity and Water Authority

---

# **HAND BOOK**

on EHV overhead line  
and underground cable  
protective regulations

---

# Contents

<b>ABOUT THIS BOOK</b>	<b>6</b>
<b>TRANSMISSION LINES &amp; ACCESSORIES</b>	<b>7</b>
1.1 Underground Cables.....	8
1.2 Overhead Lines.....	10
1.3 Underground existing EHV services - Installation methods.....	11
1.4 Accessories.....	19
<b>HAZARDOUS FACTORS WHILE WORKING NEAR TRANSMISSION LINES</b>	<b>23</b>
2.1 Serious Hazards.....	24
2.2 Hazard Levels.....	25
2.3 Precautionary measures to eliminate hazards.....	26
<b>NOCs &amp; GUIDELINES ON TRIAL PIT &amp; OHL VERIFICATION</b>	<b>29</b>
3.1 About NOCs.....	30
3.1.1 Definitions.....	30
3.1.2 Purpose.....	30
3.1.3 Scope.....	30
3.2 Different NOCs.....	30
3.2.1 Design NOC.....	30
3.2.2 Trial Pit NOC.....	30
3.2.3 Construction NOC.....	35
3.2.3A Design and Build - Building permits system(BPS).....	35
3.2.3B RTA auto-approved NOC.....	36
3.2.4 Revalidation or Renewal of Expired Construction NOC.....	36
3.3 Information.....	36
<b>REQUIREMENTS BEFORE &amp; DURING WORK NEAR TRANSMISSION LINES</b>	<b>37</b>
4.1 Work start notification.....	38
4.2 Essential measures required before starting work.....	38
<b>UNDERGROUND CABLE IDENTIFICATION</b>	<b>38</b>
<b>OHL IDENTIFICATION</b>	<b>38</b>
<b>UNDERGROUND CABLES</b>	<b>38</b>
1. Vehicle/machinery movement.....	39
2. Material storage/soil dumping.....	39
3. Flammable/inflammable items.....	39
4.3 Obtaining work start permission from patrolling team.....	40

<b>IMPLEMENTATION OF NOC CONDITIONS &amp; PRECAUTIONARY MEASURES</b>	<b>43</b>
5.1 Patrolling.....	44
5.1.1 Routine Patrolling.....	44
5.1.2 Emergency Patrolling.....	44
5.1.3 Intensive Patrolling.....	44
5.1.4 Special Patrolling.....	44
5.2 Pre-Commission Inspection.....	44
5.3 Contractors' Work Supervision.....	45
5.3.1 Work Supervision Request.....	45
5.3.2 Critical Site Supervision.....	45
5.4 Site Instruction Notice.....	45
5.5 Notice to Stop Work.....	47
5.6 Awareness Tool Box talk & meeting with contractors.....	48
<b>ACTIONS AGAINST VIOLATORS</b>	<b>49</b>
6.1 Legal Requirements.....	50
6.2 Black Points System.....	51
6.2.1 Action against violators who fall under Category A:.....	51
6.2.2 Action against violators who fall under category B:.....	51
6.2.3 Action against violators who fall under category C:.....	52
6.3 Green points system.....	52
<b>SERVICES PROVIDED BY TLM &amp; C</b>	<b>55</b>
7.1 Trial pit/OHL Verification & Supervision.....	56
7.1.1 Prior Notice, Supervision for trial pit work and verification for the trial pit.....	56
7.1.2 Getting confirmation.....	56
7.1.3 Work Hours.....	56
7.2 Construction Work Supervision.....	56
7.2.1 Prior notice, supervision for OHL and cable line protection works.....	56
7.2.2 Getting confirmation.....	56
7.2.3 Work Hours.....	56
7.2.4 Emergency Utility repairs.....	57
7.2.5 Awareness/training sessions.....	57
<b>LIST OF ABBREVIATIONS</b>	<b>58</b>
<b>CONTACT US</b>	<b>59</b>

## ABOUT THIS BOOK

This book is a guide to the protection regulations for extra-high-voltage (EHV) overhead lines and underground cables for contractors, consultants, strategic partners, as well as anyone who is working on or near DEWA's electricity transmission network. This 4th edition contains the updated work processes and requirements of DEWA's Transmission Line Maintenance Patrolling department. It provides the necessary information to ensure that completed projects conform to these regulations and necessary information, measures, documents, as well as all the criteria to ensure their successful completion.

### **How this book will help you**

This book informs you about the procedures and requirements to ensure your work is done safely to avoid accidents and potential blackouts and minimise risk.

# CHAPTER 1

---

## TRANSMISSION LINES & ACCESSORIES

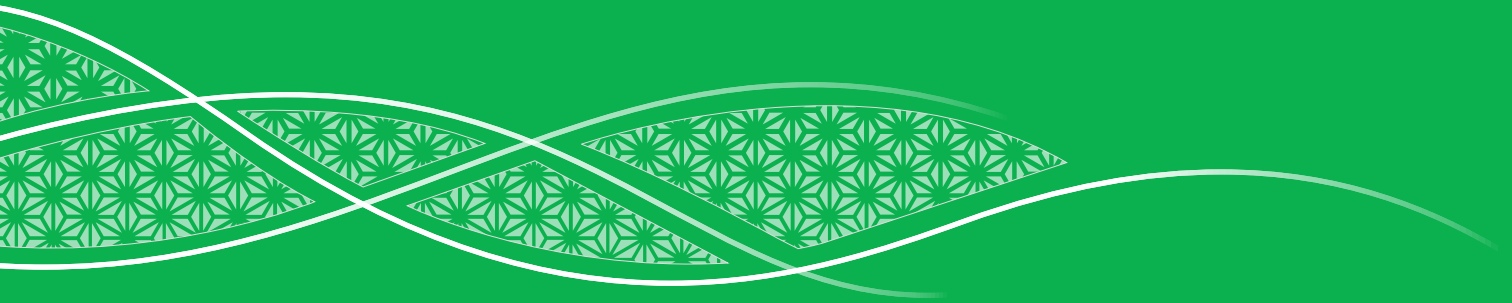

# TRANSMISSION LINES & ACCESSORIES

## 1.1 Underground Cables

- a) There are 2 types of Underground Cables:  
Power & Communications

### Power Cables

- b) Power cables have 2 voltages: 400kV and 132kV.  
c) Currently, DEWA uses XLPE cables (Fig a & b).

Please note that cable detectors cannot detect power cables when they are not live.

- a. 400kV XLPE Cable  
b. 132kV XLPE Cable

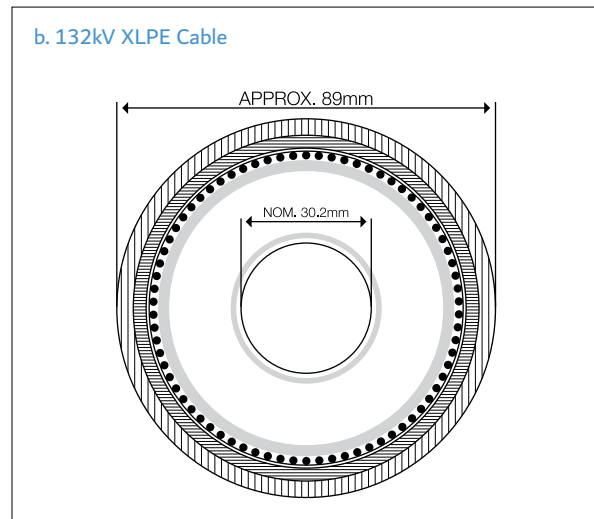
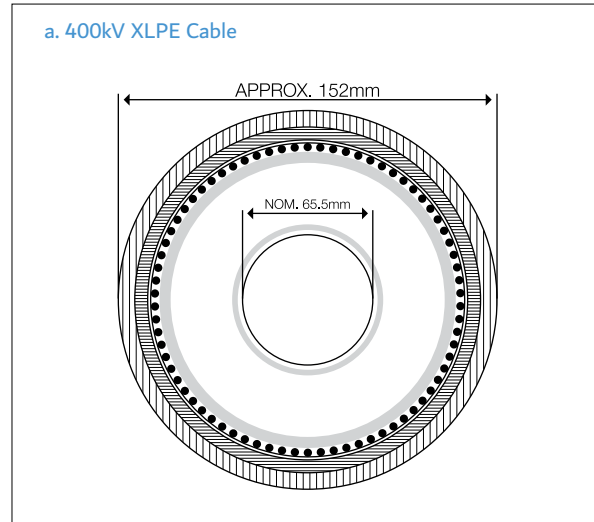

### Communication cables

DEWA uses two types of communication cables:

1. Fiber-optic cable (Fig c)
2. Pilot cable (Fig d)

Note: Fiber-optic and Pilot cables cannot be detected by cable detectors, even when live

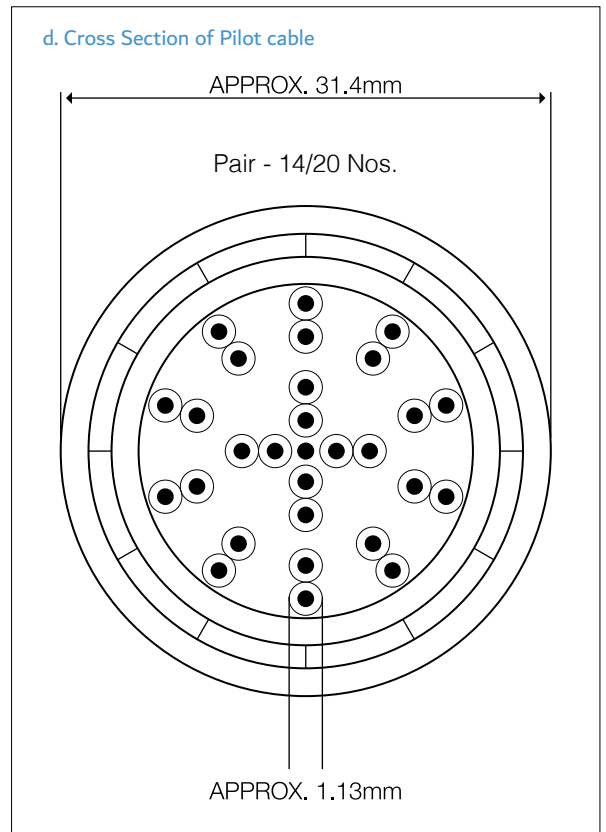
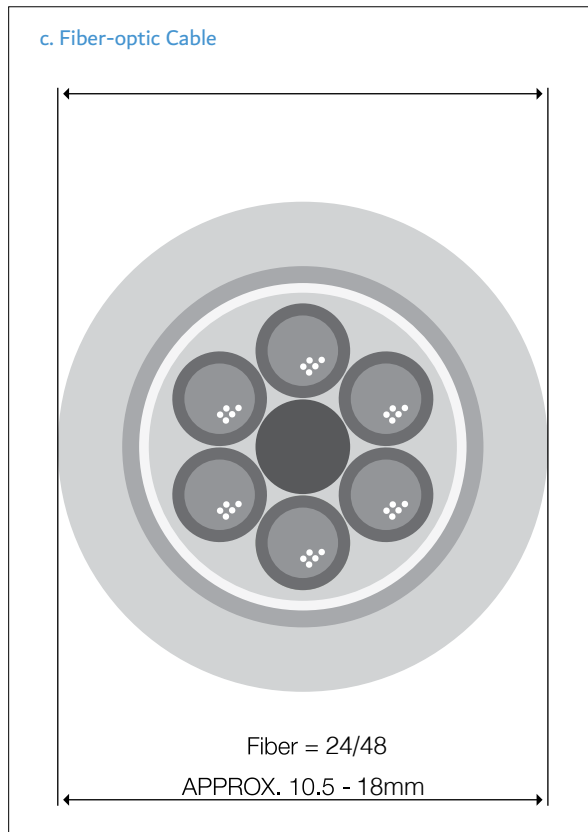

# TRANSMISSION LINES & ACCESSORIES

## 1.2 Overhead Lines

DEWA has two voltages for overhead lines: 400kV and 132kV. Overhead Lines are either

1. Tubular Monopole Tower: 400kV (Fig b)
2. Steel Lattice: Tower - 400kV (Fig a) / 132kV (Fig d) or Gantry Tower - 400/132kV (Fig c)

a. 400kV Overhead Transmission Tower



Double Circuit

Single Circuit

b. 400kV Tubular Monopole Tower



c. 400/132kV Gantry Tower



d. 132kV Steel Lattice (Double Circuit Tower)



## 1.3 Underground existing EHV services - Installation methods

400 and 132kV - Power/Fibre/Pilot cables:

- a) In Tunnels 400kV
- b) In 2-metre & 1.5m wide concrete troughs -132kV
- c) In 50cm troughs for congested areas-132kV
- d) In HDPE duct by directional drilling methods - 132kV
- e) In PVC ducts with concrete surround duct bank-132kV
- f) In direct buried conditions-132kV

### a. 400kV cable laid in tunnel

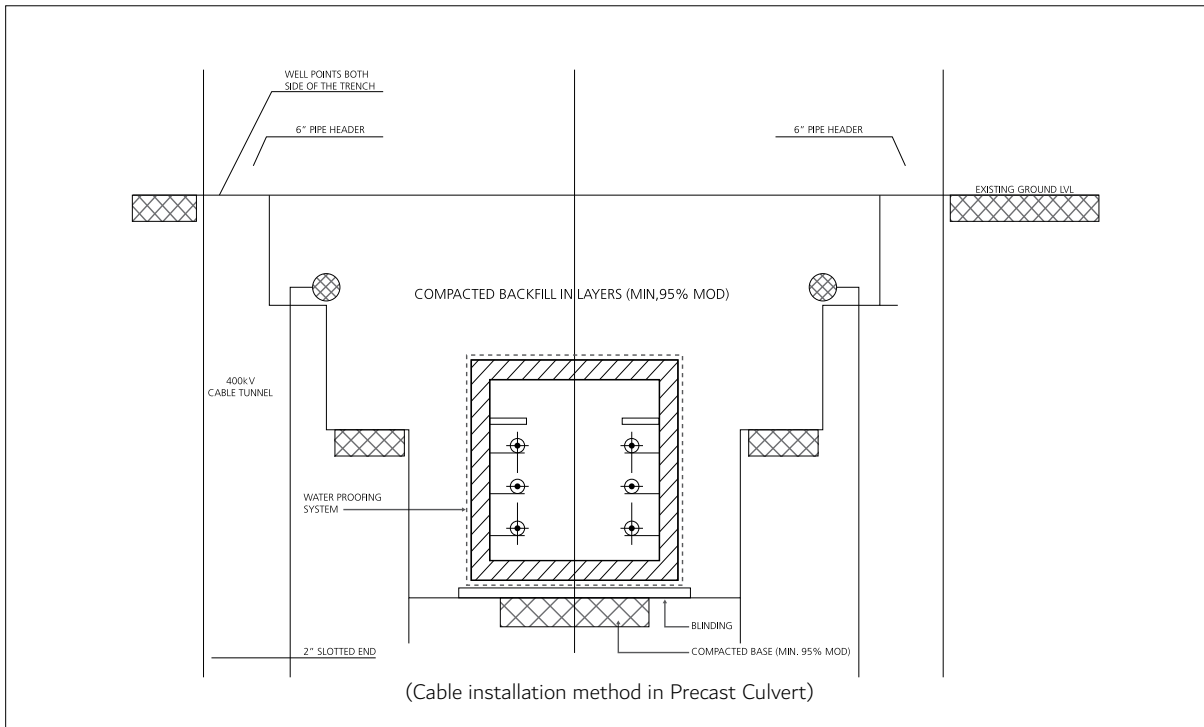

# TRANSMISSION LINES & ACCESSORIES

## b. 132kV cables laid in concrete troughs

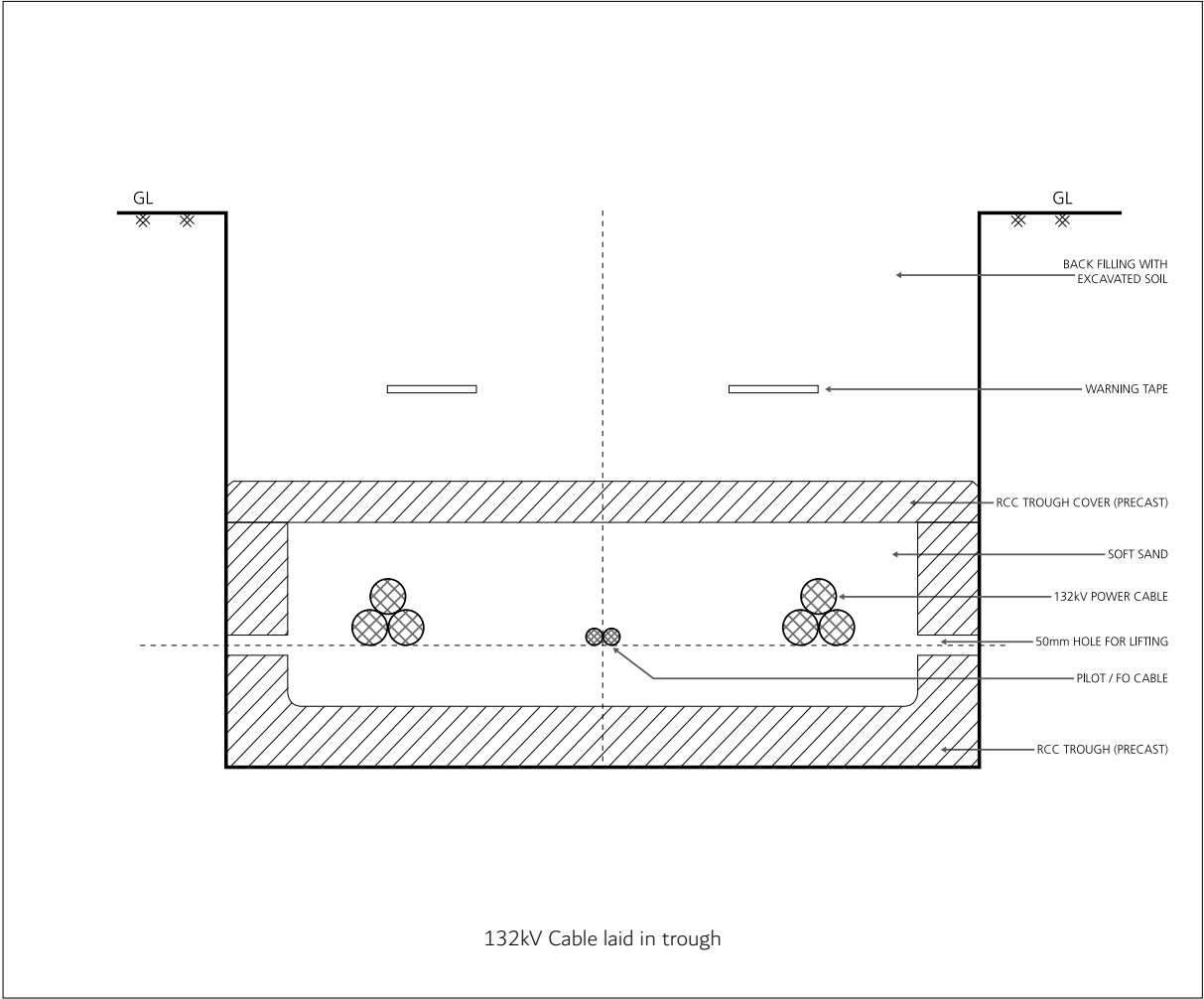

c. 132kV Cables laid in 50cm troughs in congested areas

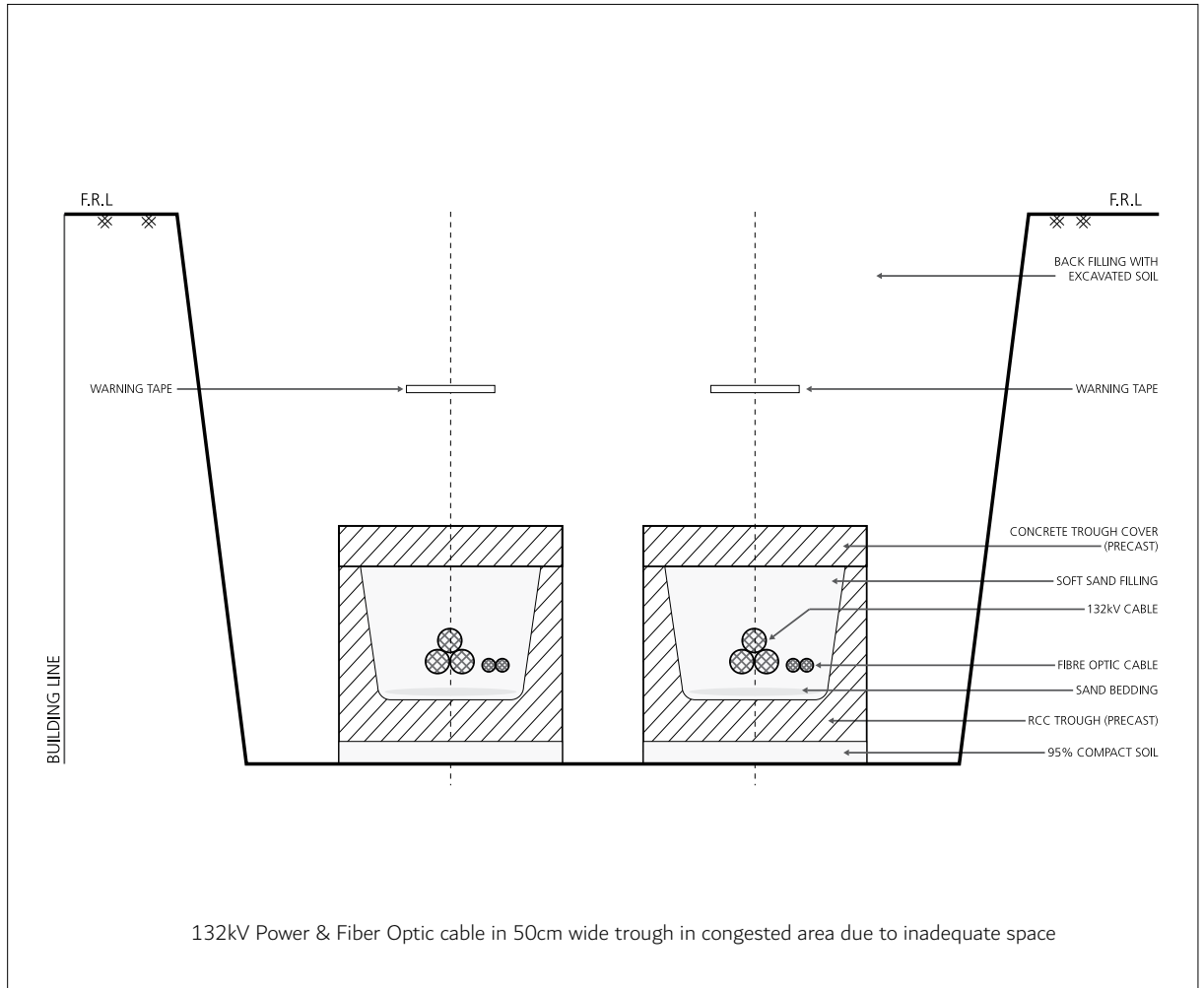

# TRANSMISSION LINES & ACCESSORIES

d. In High Density Polyethylene (HDPE) ducts by directional drilling method

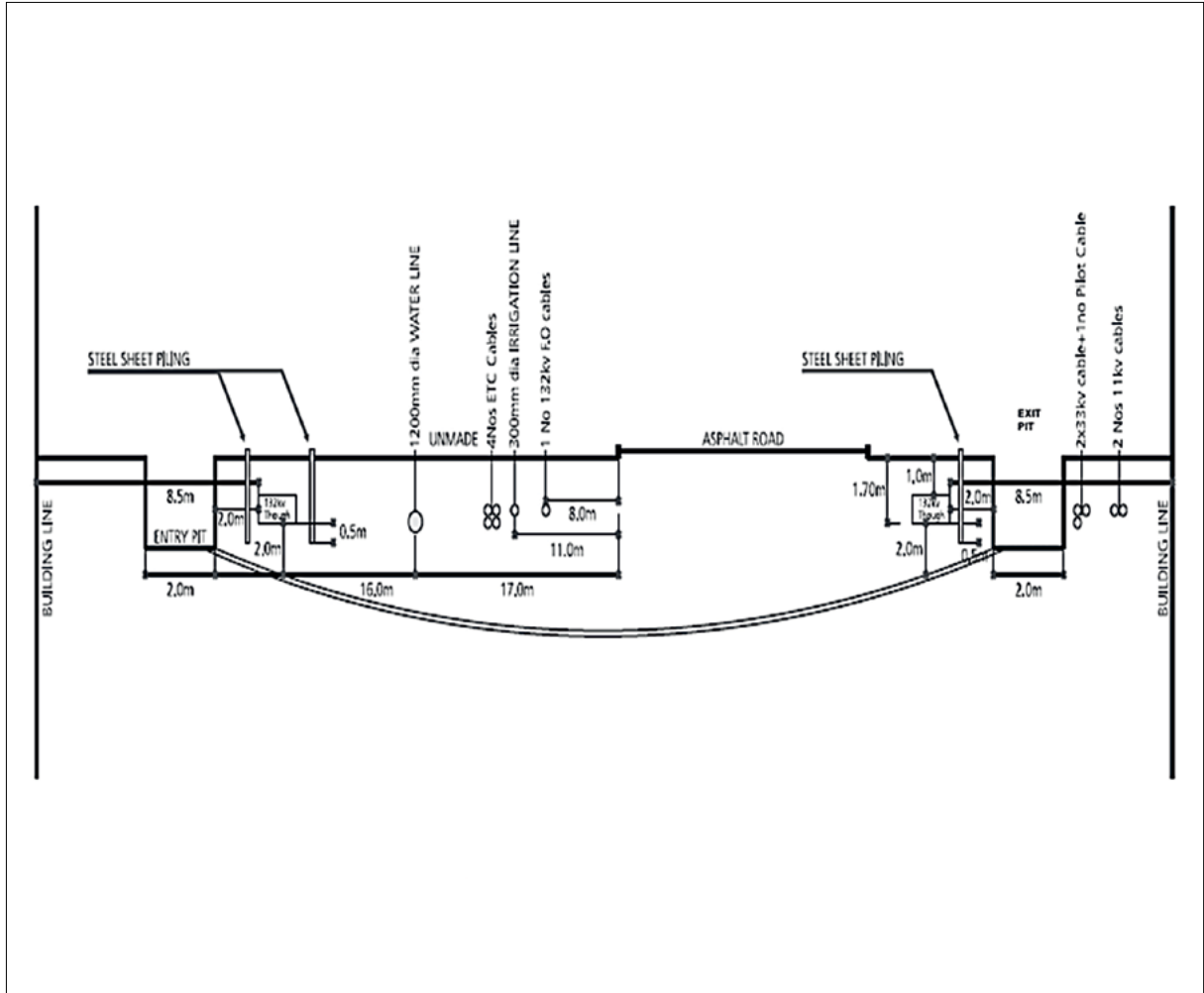

e. 132kV Power and FO cables laid in PVC ducts with surrounding concrete duct banks

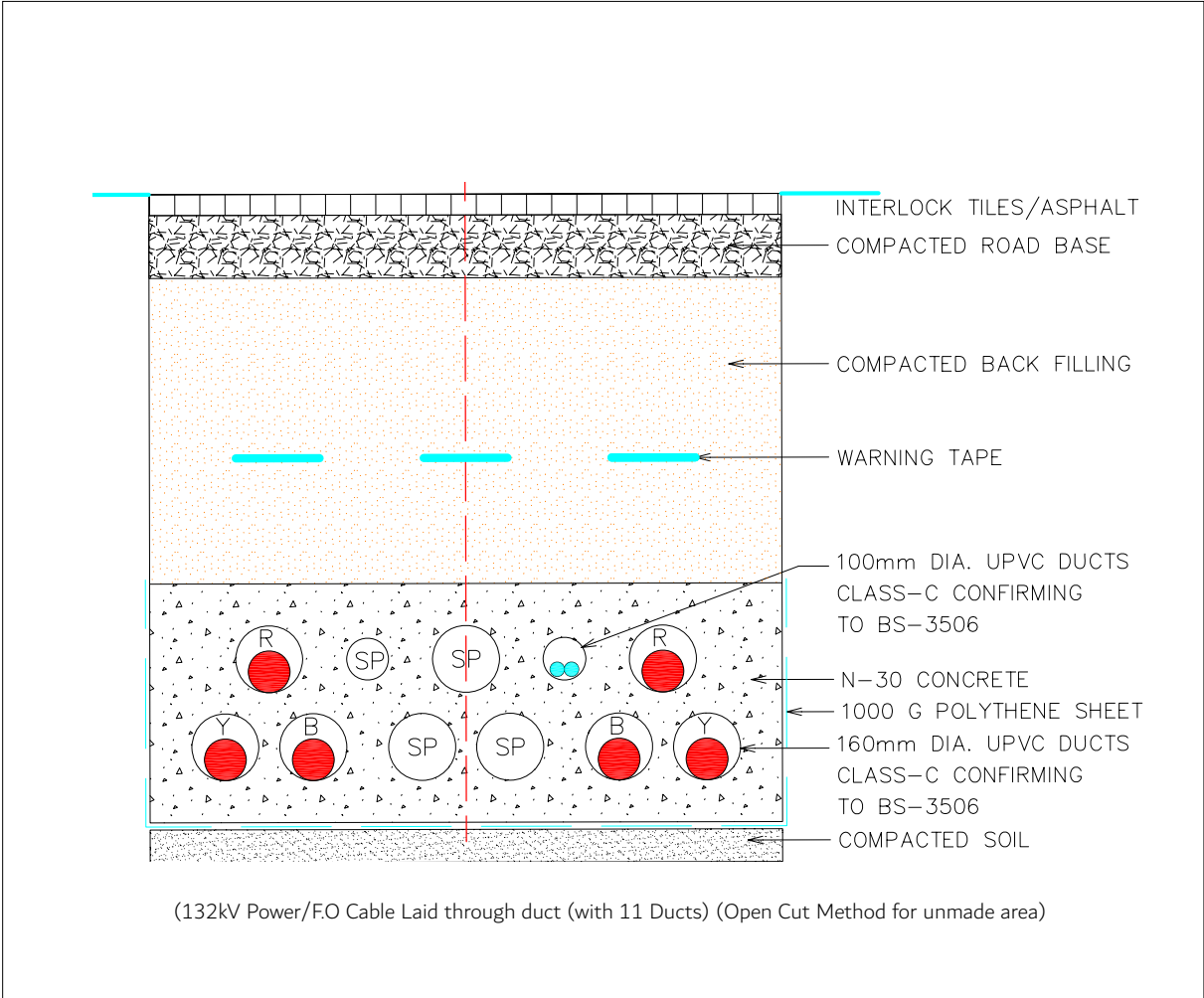

# TRANSMISSION LINES & ACCESSORIES

f. 132kV Power, Pilot and FO cables laid in directly buried conditions

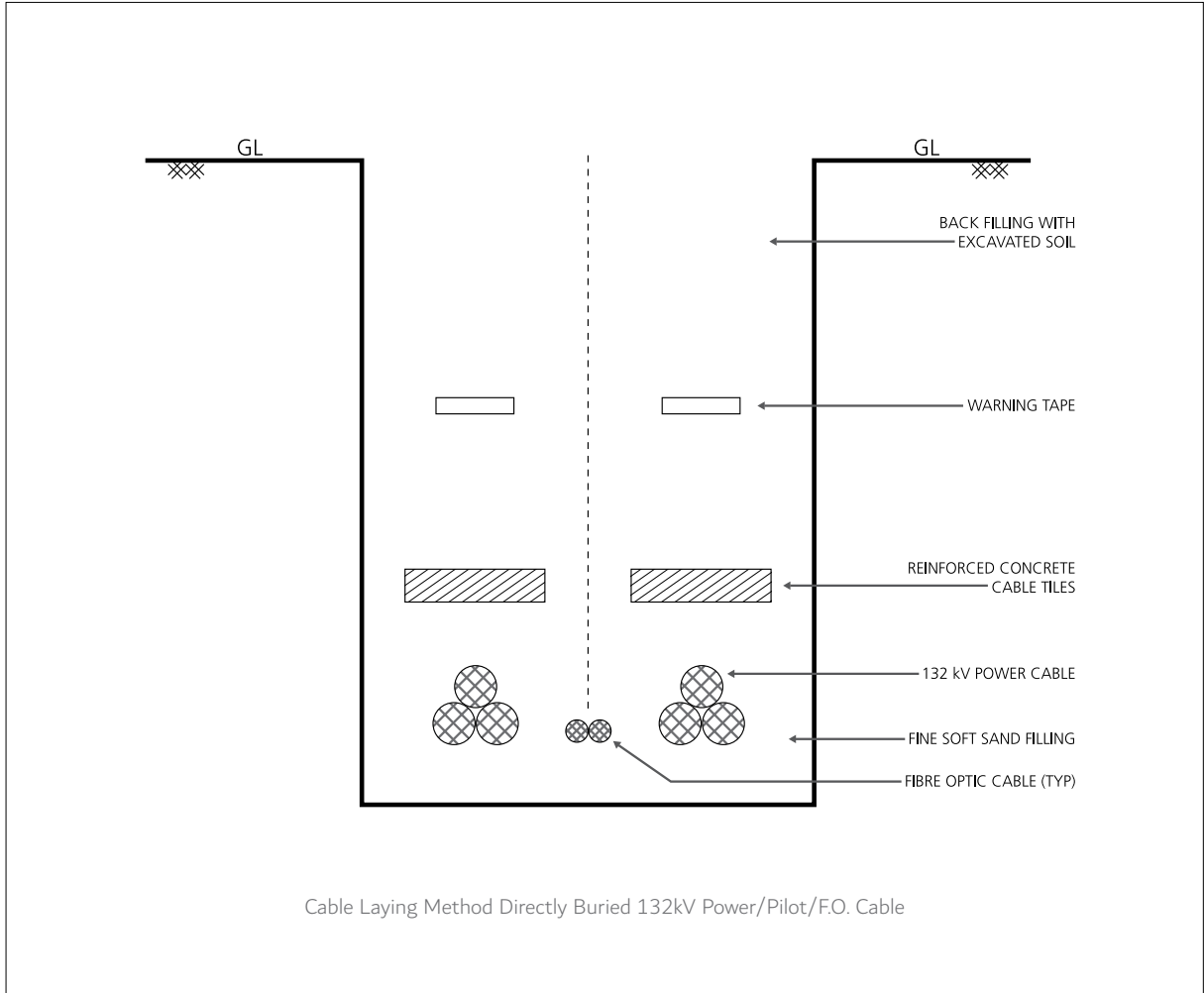

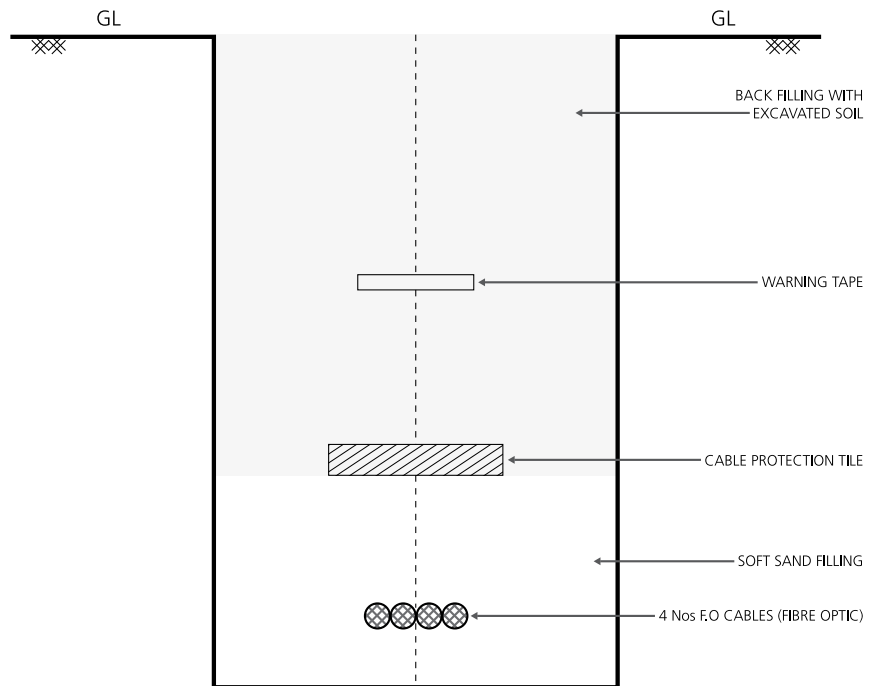

Cable Laying Method for Directly Buried 132kV F.O. Cable

# TRANSMISSION LINES & ACCESSORIES

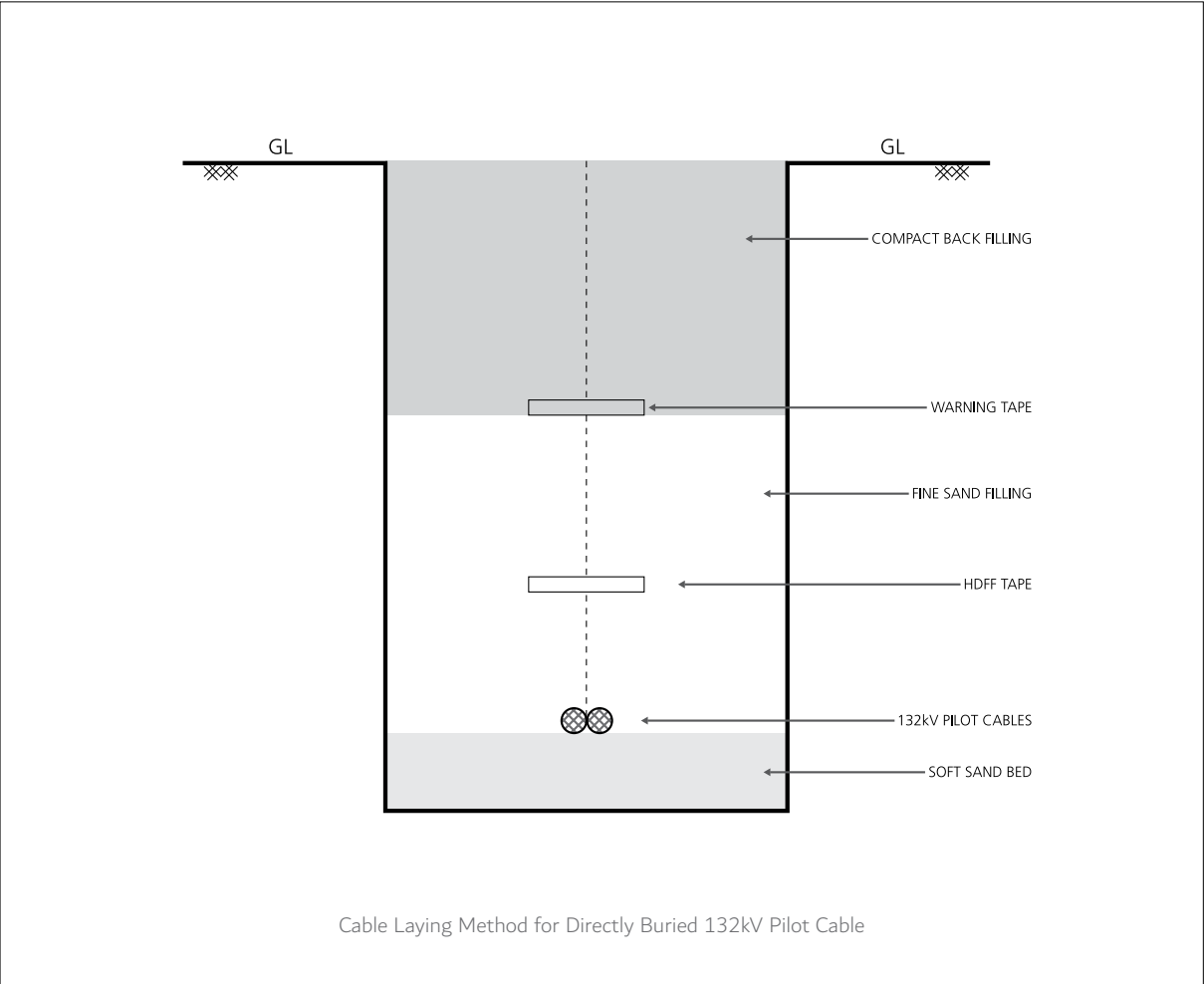

## 1.4 Accessories

### A. Cable Accessories

#### 1.4.1 Cable Joints

Cable joints are integral parts of the Transmission underground lines system as a whole.

**Note:** A joint is a sensitive point in transmission cable systems. Maintaining and properly protecting the joint area ensures the reliability of the power supply.

Normally, a power cable joint is enclosed in 2.4-metre wide concrete troughs. Some joints are enclosed in troughs, with some access via manholes. Joint locations are identified with red and white route markers for all types of installation. (Fig 1.4.1.A)

#### 1.4.2 Earth Link Boxes

This is one of the accessories for the transmission system used to easily test cable sheaths.

#### 1.4.3 Types of installation of link box enclosures

- a. Vertical mounted (Figure: 1.4.3A,1.4.3A.1)
- b. Flush mounted (Underground) (Figure: 1.4.3B)

#### 1.4.4 Cable Route Marker

##### (Power, Fiber Optic, or Pilot Cables)

- a. This is used for cable route identification and helps to indicate the presence of transmission cables. There are two types of route markers:

1. Surface or pole mounted (Figure 1.4.4A)
2. Flush mounted (Figure 1.4.4B)

- b. Install surface or pole route markers for direct buried or cable troughs under any un-paved area.
- c. Install concrete flush cable route markers for direct buried or cable troughs under any paved areas, roadways, and parking, with suitable markings for straight and angle runs and cable joints.
- d. Install all types of route markers at 100-metre intervals for straight routes. Further, a single marker is installed along the centre of the cable route.
- e. Install Pole type HDD markers to identify HDD laid routes. (Figure: 1.4.5)
- f. Install Pin type markers to identify routes laid in Asphalt (Figure: 1.4.6)

#### 1.4.1 A 132kV Cable joint location



# TRANSMISSION LINES & ACCESSORIES

1.4.3A Vertical mounted link box with steel bollard protection



1.4.3A.1 Vertical mounted link box with steel crash barrier protection on the side of a road.



1.4.3B Flush type Link box



1.4.4A Surface-pole-type route markers installed at 100-metre intervals.



1.4.4B Flush type route markers on paved areas



1.4.5 Pole type HDD marker



1.4.6 Pin type markers



## B. Overhead Line Accessories

1.4.7 - Permanent height limit gantry at road crossing is installed to restrict height of vehicle/machineries. (Figure 1.4.7A and 1.4.7B)

1.4.7A Permanent-height-limit gantry at road crossing



1.4.7B Permanent height-limit gantry at a road crossing



# TRANSMISSION LINES & ACCESSORIES

## 1.4.10 Installation of signboards prohibiting activities in overhead line corridors



## 1.4.11 Contractors doing excavation work must not disturb or damage earthing systems within a 5-metre vicinity of tower leg foundations.

### What's next?

In the next chapter, we cover the different hazards that affect transmission line and the precautionary measures to mitigate them.

The assessment of hazard risks are a pre-requisite for any working party to consider when planning any work affecting transmission lines.

# CHAPTER 2

---

## HAZARDOUS FACTORS WHILE WORKING NEAR TRANSMISSION LINES

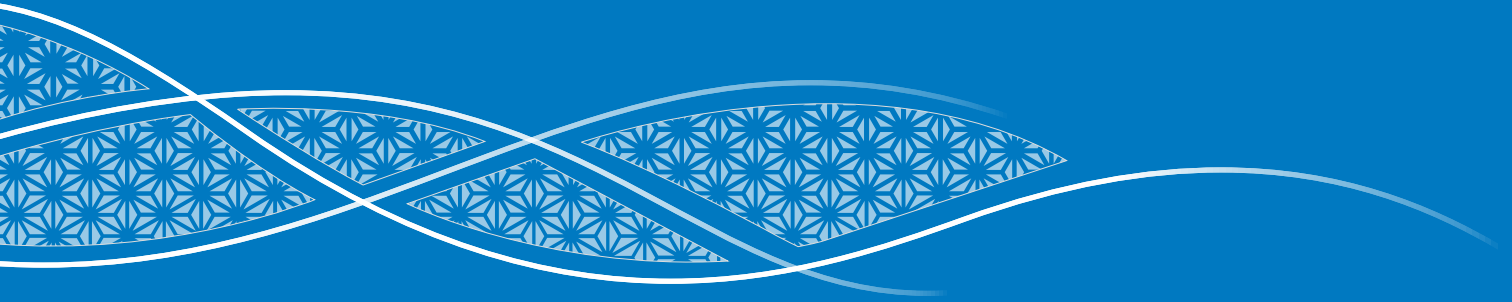

# HAZARDOUS FACTORS WHILE WORKING NEAR TRANSMISSION LINES

These are the most common hazards that cause damage to EHV transmission lines due to unsafe construction activities:

## 2.1 Serious Hazards

- a) Works within and around Transmission lines without obtaining NOC or obtaining DEWA TLM-LP work clearance, or violating NOC conditions and method statements.
- b) Works without verification or identification of underground cables.
- c) Works without verification or checking clearance of overhead lines.
- d) Usage of machinery for excavation over or in close vicinity of Transmission lines.



## 2.2 Hazard Levels

Sl.No.	Hazards	Hazard level
a	Works within and around Transmission lines-without prior notification to DEWA , without obtaining NOCs, without work permission from patrolling teams, causing violation of NOC conditions and Method statements	High
b	Work without verification or confirmation of the underground cables.	High
c	Work without verification or checking clearance of over headlines	High
d	Use excavation machinery on or Cranes near transmission lines	High

# HAZARDOUS FACTORS WHILE WORKING NEAR TRANSMISSION LINES

## 2.3 Precautionary measures to eliminate hazards

Sl.No.	Precautionary measures	Hazard level
a	DEWA allows contractors to work within and around transmission lines: <ul style="list-style-type: none"><li>- with prior notification,</li><li>- valid NOC,</li><li>- work-permission clearance from respective patrolling teams</li><li>- following all NOC conditions or method statement</li></ul>	Low
b	All underground cables are identified and protected in work areas (Figure: 2.3.a)	Low
c	OHL clearance confirmed and height-limited gantry provided to work under OHL (Figure: 2.3.b)	Low
d	Based on the NOC, contractors should ensure that only manual excavations are done on or near transmission lines. Contractors must receive separate approval to work with machinery / Crane if the approved construction NOC doesn't mention any of the required details, cross sections, or clearances. (Figure: 2.3.c)	Low

## Site photos - Precautionary measures

2.3.a Identification & Barricading



2.3.b Clearance confirmed  
& Height limit gantry  
provided



2.3.c Manual excavation



# HAZARDOUS FACTORS WHILE WORKING NEAR TRANSMISSION LINES

## **What's next?**

In the next chapter, we outline different types of useful NOCs for site and project works.

We'll also explain the requirements for the processes for trial pit- and OHL-verification. We'll also cover their purpose and guidelines that need to be followed until the process is completed.

These details are vital and the first step towards receiving the construction NOC for the works.

It also covers the verification stage before issuing a NOC, which is a very important precautionary measure for eliminating hazardous factors. This includes the study and mitigation of the risks involved when executing any work in a safe manner on or near the vicinity of transmission lines.

# CHAPTER 3

---

## NOCs & GUIDELINES ON TRIAL PIT & OHL VERIFICATION

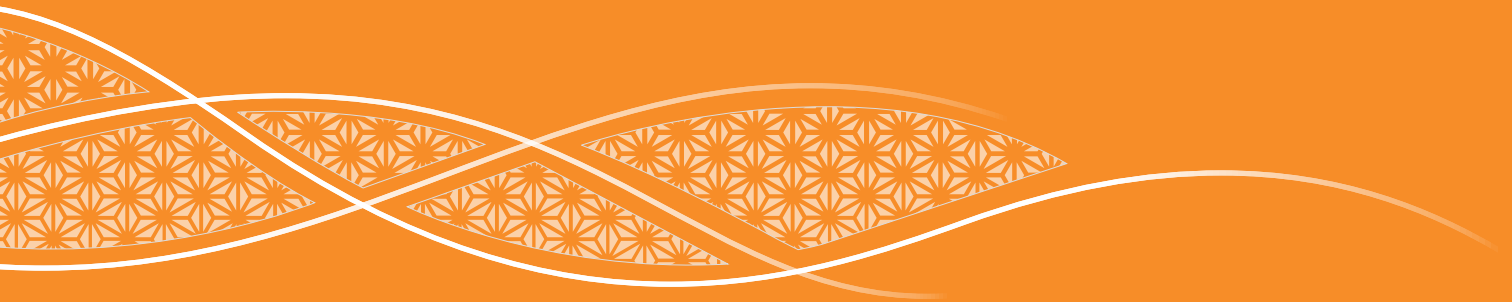

# NOCs & GUIDELINES ON TRIAL PIT & OHL VERIFICATION

## 3.1 About NOCs

### 3.1.1 Definitions

The No Objection Certificate is abbreviated as a NOC and is defined as written permission issued by the Infrastructure Information and Permit and Connection Services departments at DEWA to any requesting party to carry out proposed construction activities as outlined in the submitted and approved drawings and documents.

### 3.1.2 Purpose

Issuance of NOC prior to construction works provides the first line of protection to all existing DEWA's assets from proposed construction, as it contains sets of regulatory requirements, protective rules, precautionary measures, and engineering construction standards that require clear understanding by all constructors and that they must adhere to the NOC's terms and conditions.

### 3.1.3 Scope

The extent of application of approved NOC are those areas within or in close proximity to the transmission line networks (400/132kV Overhead Line and underground cables).

## 3.2 Different NOCs

### 3.2.1 Design NOC

Design NOC is a permission given to consultants and organisations' utility departments to proceed with their proposed project. Their Tender Design Drawings outline

the approximate locations and clearance of all the existing transmission underground cables and overhead lines.

### 3.2.2 Trial Pit NOC

A trial Pit NOC is permission given to the contractor to proceed digging-in the number of Trial Pits based on the proposed scope of work limit outlined on the site as directed by DEWA's patrolling staff.

#### A. Purpose of Trial Pits

Digging trial pits is the best way of confirming the real identification and exact location of DEWA's existing assets in relation to the proposed construction work. These are the main parameters used in the evaluation and approval of the subsequent Construction NOC. However, GIS and As-built drawings can also be referred to, in most cases, depending on site conditions.

#### B. Requirements for Trial Pit Preparation

- a. Contractors should only dig trial pits under the supervision of DEWA's representatives: the TLM & C - Lines Patrolling staff. According to the scope of work, the supervisor will mark the trial pit location.
- b. The mandatory supervision specified in the previous point must be requested using DEWA work intimation request format and sending an e-mail to DEWA, at least 2 working days before starting any digging activities. (Annex 3.1.1)
- c. Trial Pit is a trench made across and over the

suspected location of underground cable, trough, joint, etc. (Figure: 3.1.2)

d. Trial pits should only be dug or to be carried manually by hand to ensure that the buried cables at unconfirmed location may not be damaged. (Figure: 3.1.3)

### Annexure 3.1.1 Work Intimation request

WORK INTIMATION REQUEST			
<b>Transmission Power (400/132 KV)</b> <input type="checkbox"/> OHL <input type="checkbox"/> Cable Route	<b>Attn To:</b> Manager Transmission Line Handling	<b>Email:</b> th.supeintekin@dewa.gov.ae	<input type="checkbox"/> Trial Pit Work Start Notification <input type="checkbox"/> Trial Pit / Site Verification <input type="checkbox"/> Construction Work Start Notification <input type="checkbox"/> Site Work Supervision
<b>Distribution Power (33/11/6.6 KV)</b> <input type="checkbox"/> OHL <input type="checkbox"/> Cable Route	<b>Attn To:</b> Sr. Manager Distribution Maintenance Dubai Zone	<b>Email:</b> pat@tding.djm@dewa.gov.ae <small>For Work Intimation Request Start this format: t@tding.djm@dewa.gov.ae</small> t@tding.djm@dewa.gov.ae	<input type="checkbox"/> Trial Pit Work Start Notification <input type="checkbox"/> Trial Pit / Site Verification <input type="checkbox"/> Construction Work Start Notification <input type="checkbox"/> Site Work Supervision
<b>LV Cables (400/230 V)</b> <input type="checkbox"/> Cable Route	<b>Attn To:</b> Manager Network Modification	<b>Email:</b> t@tding.djm@dewa.gov.ae	<input type="checkbox"/> Trial Pit Work Start Notification <input type="checkbox"/> Trial Pit / Site Verification
<b>Fiber Optic Cable Services (FOC)</b> <small>(200/132/6.6 KV/110V/24 WAY HDPE)</small> <input type="checkbox"/> Standalone Fiber Optic Cable (FOC Route)	<b>Attn To:</b> Dy. Manager TelecomKOTS M&C	<b>Email:</b> t@tding.djm@dewa.gov.ae	<input type="checkbox"/> Trial Pit Work Start Notification <input type="checkbox"/> Trial Pit / Site Verification <input type="checkbox"/> Construction Work Start Notification <input type="checkbox"/> Site Work Supervision
<b>Water Services</b> <input type="checkbox"/> Distribution <input type="checkbox"/> Transmission <input type="checkbox"/> Water SCADA F.O, PVC / HDPE & 24 WAY HDPE	<b>For Trial Pit Verification Attn To:</b> Sr. Manager M&C Department	<b>Email:</b> mbe.zoc@dewa.gov.ae	<input type="checkbox"/> Trial Pit Work Start Notification <input type="checkbox"/> Trial Pit / Site Verification <input type="checkbox"/> Construction Work Start Notification <input type="checkbox"/> Site Work Supervision
<b>For Site Supervision Attn To:</b> Sr. Manager M&C Department	<b>Email:</b> mbe.zoc@dewa.gov.ae	<b>For Water SCADA F.O, PVC / HDPE &amp; 24 WAY HDPE Attn To:</b> Dy. Manager TelecomKOTS M&C	<b>Email:</b> t@tding.djm@dewa.gov.ae
<b>Request Date :</b> _____	<b>DEWA NOC No. &amp; Issue date date :</b> _____		
<b>Project No. &amp; Title / Name :</b> _____			
<b>Description of the work :</b> _____			
<b>Consultant Name :</b> _____		<b>Contractor Name :</b> _____	
<b>Tel :</b> _____	<b>Fax :</b> _____	<b>Tel :</b> _____	<b>Fax :</b> _____
<b>RE Name :</b> _____		<b>Project Manager Name :</b> _____	
<b>Mobile No :</b> _____		<b>Mobile No :</b> _____	
<b>Email :</b> _____		<b>Email :</b> _____	
<b>Location / Community of work with nearest landmark :</b> _____			
<b>Work Location Coordinate :</b> _____			
<b>Length of work under this permit (Max. 1000 m) :</b> _____		<b>No. of Trial pits to be verified at site :</b> _____	
<b>Requested Period for this Intimation (Work shall be done during DEWA office hours only)</b> _____		<b>Start Date &amp; Time (*):</b> _____ 00:00	
		<b>End Date &amp; Time :</b> _____ 00:00	
<b>Confirmation Checklist (To be filled by Consultant / Developer for work start notification)</b>			
	Yes	No	N/A
All DEWA services located in the working location	<input type="checkbox"/>	<input type="checkbox"/>	<input type="checkbox"/>
Ensure no materials stored above DEWA services / corridor	<input type="checkbox"/>	<input type="checkbox"/>	<input type="checkbox"/>
DEWA NOC, GIS drawing & TP Verification on site	<input type="checkbox"/>	<input type="checkbox"/>	<input type="checkbox"/>
DEWA sign board / markers placed on site & protected	<input type="checkbox"/>	<input type="checkbox"/>	<input type="checkbox"/>
Water valve chamber / Surface box on site (Exposed)	<input type="checkbox"/>	<input type="checkbox"/>	<input type="checkbox"/>
Exposed services (If any) protected and supported as per approved DEWA specification	<input type="checkbox"/>	<input type="checkbox"/>	<input type="checkbox"/>
Working area barricaded at site & Safety measures were properly taken	<input type="checkbox"/>	<input type="checkbox"/>	<input type="checkbox"/>
No. of pipeline & size in the working area			
No. of cables / route in the working area (400/132/33/11/6.6 KV / 400/230 V)	<b>Transmission (EHV)</b> 400 kv : _____	<b>Distribution (HV)</b> 33/11/6.6 KV : _____	<b>LV Cables</b> 400/230 V : _____

Remarks (If any) :		
<p><b>Working Party Acknowledgement :</b></p> <ul style="list-style-type: none"> <li>I hereby, assure that I have personally checked and verified all the above mentioned details and also confirm that the excavation work close to DEWA services will be done manually by using hand tools only.</li> <li>It is known to me that, the standby supervision request to be sent to DEWA after mobilization of manpower, logistics, tools and work readiness at site.</li> <li>Moreover, it is understood that, as per DEWA's mandatory requirement, the work needs to be started at site by the contractor on the specified requested time period, after availing standby site supervisor from DEWA.</li> <li>This permit is requested for the area marked in the drawing No: _____</li> </ul>		
<p><b>Contractor site In-charge Details :</b></p>		
<b>Name of the Engineer :</b> _____	<b>Name of the Foreman :</b> _____	
<b>Mobile No:</b> _____	<b>Mobile No:</b> _____	
<p><b>(Note : Either the engineer or the foreman must be available on site all the time during work execution)</b></p>		
<p><b>Note :</b></p> <ol style="list-style-type: none"> <li>Work Intimation request should be forwarded to the concerned department two working days in advance.</li> <li>(*) Verification request for FOC / FOC Duct laid along with EHV Services should be forwarded to Transmission Power.</li> <li>(*) Verification request for FOC / FOC Duct laid along with HV Services should be forwarded to Distribution Power.</li> <li>(*) Date and time will be confirmed by the concerned department for trial pit verification and site work supervision.</li> <li>If the requested period is beyond the office normal working hours. Accordingly, justifications to be attached along with request for approval.</li> </ol>		
<p><b>Site Communication Channel :</b></p>		
<b>Service Type</b>	<b>Trial Pit Verification</b>	<b>Site Supervision</b>
Transmission Power	04-3227929 / 054-7917269 04-3221547 / 054-7917359	04-3227929 / 054-7917269 04-3221547 / 054-7917359
Distribution Power (6.6/11/33 KV)	04-3227494 / 04-322969	Cable 04-3227496 / 04-322969 OHL 04-3227511 / 04-3227540
Fiber Optic Cable Services (FOC)	04-3228062 / 04-3228431 / 04-3228006	-
Water Services	04-3220438 / 04-3220465 050-7282829 / 050-6501191	04-3220438 / 04-3220465 050-7282829 / 050-6501191

# NOCs & GUIDELINES ON TRIAL PIT & OHL VERIFICATION



Fig 3.1.2 Locating 132kV cable through Trial Pit.



Fig 3.1.3 Manual excavation for Trial Pit.



### C. Trial Pit Verification

After exposing all existing cables, troughs, and joints, DEWA's representative (LP – supervisor) needs to confirm the exact location of the cables, depth, coordinates and clearance (vertical/horizontal) and whether it is the same as incorporated in the proposed scope of the work limit drawings. The same supervisor should sign and stamp the confirmation. After Trial pit verification is complete, trenches to be backfilled as per RTA / DEWA standards.

Contractors should submit the verified trial pit details to DEWA with their application for the construction NOC.

#### Special Cases:

1. If the 132kV cable cannot be found (HDD area), DEWA's supervisor will write in the verification, that

the cable has not been found at the expected depth

2. Additionally, DEWA can provide the coordinates from the As Built drawings for trial pits, if required.
3. As a final resort, the sensor method can be used for identification of 132kV cables.

Fig 3.1.4 Trial pit verification.



# NOCs & GUIDELINES ON TRIAL PIT & OHL VERIFICATION

## D. OHL Clearance verification

The OHL Clearance verification confirms the horizontal and vertical clearance details shown in the proposed scope of work. This shows maximum height, radial clearance and how close contractors can work near and under OHLs. This will be verified and signed by the LP supervisor.

Contractors should submit this to DEWA with their application for the construction NOC.

## E. Guidelines on drawing preparation: (for Verification by DEWA TLM & C-LP supervisor)

Contractors should prepare the trial pit drawing details in A1 size sheet, showing the following:

### Before trial pits:

1. Contractors, when superimposing of DEWA GIS in their proposed drawings, should use one colour to show the proposed works and a different colour to show the 400/132kV lines.
2. Colour drawings should be made available at the site for verification.
3. The DEWA supervisor will review the drawing and mark the trial pits' locations on the drawing and also mark them at the actual site.

### After trial pit & during verification:

1. Trial pit numbers (TP1, 2, etc.) with coordinates of TP locations to be marked in the proposed scope of work drawings.
2. The contractor will show all the coordinates of the identified service, in the drawing for example:
  - a. For 132kV trough – provide coordinates for the 2 edges of the trough
  - b. For Joint bay - provide coordinates for the 4 corners of the bay
  - c. For HDD entry and exit pit matching points - provide the entry and exit coordinates respectively
  - d. Coordinates of Link box area
  - e. Tower foundation coordinates

### Cross section drawing:

Parallel & vertical clearance from proposed scope of work to 400/132kV lines, should be provided as a separate drawing.

Note: Any additional details (including sub-contractor details) requested by the DEWA supervisor should be included; based on site conditions.

**F. Trial pit requirements (as per below table):**

Sl.No.	Cable	Horizontal clearance from excavation edge of proposed works	Trial pits intervals are required at
1	Direct buried cables/HDD	Less than 2 metre	Min 10 metres
		Greater than 2 metre	Min 20 metres
2	Trough/duct bank	Less than 2 metre	Min 30 metres
		Greater than 2 metre	Min 50 metres
3	400kV Tunnel	Trial pit is required at min 30-metre intervals	
4	For cable route bending, joint bay/HDD& complex areas, trial pits will be advised as per site situation.		

**3.2.3 Construction NOC**

The Construction NOC allows contractors to do the construction they have requested.

**3.2.3A Design and Build - Building permits system(BPS)**

After obtaining a Design and Build - Building permits system(BPS) from RTA, Contractors should complete

DEWA Trial pit verification and obtain DEWA shop drawing approval, as mentioned in the Design & build NOC conditions when working close to 132kV cables. The scope and design for this NOC category includes fencing, site office, project signboard, temporary access, external paving and shoring work. After receiving the NOC, contractors must notify DEWA's TLM & C department, prior to the start of work at the site.

# NOCs & GUIDELINES ON TRIAL PIT & OHL VERIFICATION

## 3.2.3B RTA auto-approved NOC

The RTA issues this type of NOC for electricity and water connections for houses. Contractors should notify DEWA that they have received this NOC, and intend to start works at the site.

## 3.2.4 Revalidation or Renewal of Expired Construction NOC

This NOC is valid for 6 months only and should be revalidated 15 days before its expiry date.

Remember, it is easier to request that the NOC be revalidated than go through the complete procedure all over again.

## 3.3 Information

To make a successful submission of NOC applications, refer to the NOC Submission guideline from DEWA II&P Dept.

Please visit website - <https://www.dewa.gov.ae/en/builder/useful-tools/user-manual> for the below:

1. Infrastructure NOC Technical Manual
2. Infrastructure NOC Submission Guidelines
3. Infrastructure Projects Services Submission Guidelines
4. Infrastructure Projects Services User- Manual

## What's next?

Once you've received your NOC, you need to know what to do next to conform with its requirements. This next chapter covers these requirements to avoid any violations.

This is to ensure the best possible health and safety for everyone on site, and minimise and mitigate any hazards or risks within or near DEWA's transmission lines.

# CHAPTER 4

---

## REQUIREMENTS BEFORE & DURING WORK NEAR TRANSMISSION LINES

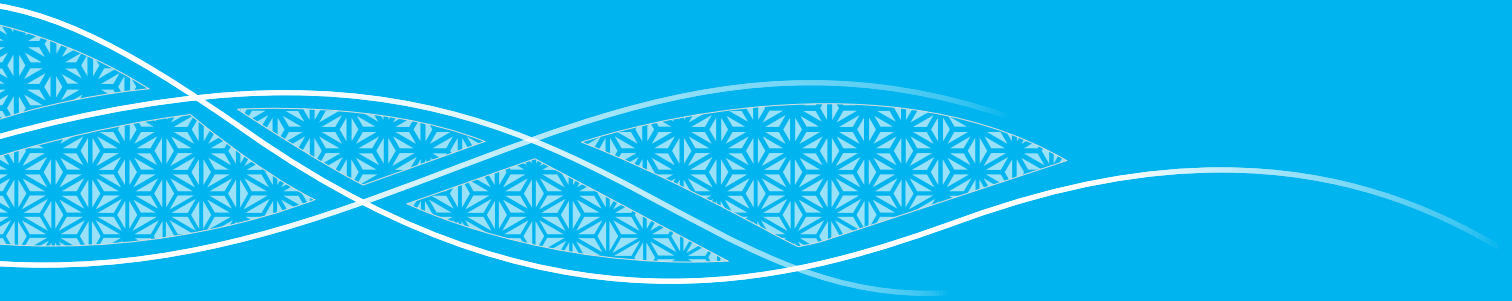

# REQUIREMENTS BEFORE & DURING WORK NEAR TRANSMISSION LINES

## 4.1 Work start notification

Information to DEWA TLM & C-LP: Every working party or contractor must notify DEWA TLM & C-LP, at least 2 working days prior to starting work.

This rule is applicable for each and every NOC received from DEWA.

The working parties should notify the TLM & C - Lines Patrolling section, with the format Work intimation request shown in page 31.

### Actions from TLM & C-LP:

The DEWA Patrolling Zone Engineer will assign a Critical Works Supervisor, to guide or to check the site and advise the contractor on implementation of the requirements that need to be completed before starting work, such as signs, barricades and safety notices.

## 4.2 Essential measures required before starting work

### A. Cable & OHL identification

#### Underground cable identification:

After receiving the NOC and before starting work, contractors should physically identify the cables based on the DEWA TLM & C-LP verified trial pits, and confirm their coordinates. For further details please see the approved NOC issued by DEWA.

DEWA supervisors can recommend additional trial pits if required. Once contractors have done this, they should mark the coordinates of the trial pits and include the following details:

- Trough edge coordinates of underground cables
- Types of cable,
- Parallel/Crossing works (above/below),
- Work clearance,
- Work limit start/End coordinates &
- Proposed work details.

These details should be included in the Danger signpost shown on page 42.

#### OHL identification:

The NOCs issued for the works affecting Overhead lines contain the verified and approved vertical and horizontal distances between DEWA assets and the scope of work. These are to be included in all signs at the site

### B. Barricading & installation of signboards and height limit gantries:

#### Underground cables:

Proper barricading with mesh, safety cones, warning tape and barriers are required. Any plastic barriers must be filled with water. Concrete barriers can be used where applicable.

Danger signposts are to be installed at regular intervals along the affected cable routes, and should be clearly

understood by everyone working there. Vehicles and Machinery are not allowed to encroach the barricaded cable route area. Signs will identify the work boundaries as defined by the NOC.

### Overhead lines

In case of machinery works, the approved vertical and radial distances mentioned in the signposts must be included on the height limit gantries and clearly displayed for everyone present.

DEWA corridor access or access roads should only be used if approved in the NOC. All vehicle and machinery movement should be confined and barricaded to limit access to the work site. Please request a TLM & C-LP supervisor to be present when doing this. Signs will identify the work boundaries as defined by the NOC.

### C. NOC availability

All working parties should make copies of the NOC and the TP verification drawings, route, cross section, method statement, sub-contractor approvals and make them available on site.

This will enable the contractor to refer to and complete the work and enable DEWA staff to permit work, as per the NOC.

Protective regulations, NOC conditions and work clearances must be strictly implemented at the work site. The DEWA TLM & C patrolling team will enforce this on a daily basis.

Any intended deviations outside of the issued DEWA NOC should be discussed with the DEWA TLM & C - Lines Patrolling Engineer, or the II&P. These must be resolved prior to any work being carried out.

### D. General Protective Requirements

The below briefly mentioned site issues are important and protection must be provided as mentioned in the NOC conditions:

#### 1. Vehicle/machinery movement

**Above cable** - Ramp protection as per NOC.

**Below OHL** - Only below height limit gantry with approved vertical clearance and also installed when machinery works are parallel to OHL, to restrict boom movement.

Direction signage required at site to indicate the access, not affecting cable/OHL.

#### 2. Material storage/soil dumping

As per NOC or designated area

**Above Cable** - this is not permitted and must not happen near the cable route

**Below OHL** - Not permitted

Signage is required on site to show the storage area.

#### 3. Flammable/inflammable items

**Above/near cable** – Not permitted

**Inside OHL corridor**- Not permitted

Please discuss and get approval for any work procedures and methods of work with the NOC centre before starting work.

# REQUIREMENTS BEFORE & DURING WORK NEAR TRANSMISSION LINES

## E. Availability of capable staff

Working parties and contractors must ensure that they deputise capable site supervisors, engineers, and safety officers on site, who understand the importance of the work being carried out in the vicinity of the transmission lines.

Working parties and contractors must understand the approved NOC to work near lines, along with the regulations, work clearances, and precautionary measures required while using machinery. They must clearly communicate this to site staff on a daily basis.

Following and abiding by DEWA staff instructions will help protect the transmission lines, and ensure that all the work is completed safely.

## 4.3 Obtaining work start permission from patrolling team

### F. Work start permission

After implementing all precautionary measures before starting the work, the Patrolling Engineer or representative will visit the contractor work site and ensure that these measures have all been undertaken.

### G. Confirmation of horizontal & vertical work clearance from Transmission lines

Working parties and contractors need to confirm the coordinates for all the transmission lines, using GPS or

Total Station, and check them with the DEWA patrolling Engineer. They should resolve any deviations noted by the Patrolling Engineer or the II&P.

### Separate approvals

Working parties should include all the machinery-related details and requirements in the shop drawings while verifying where all the transmission lines are. This prevents unnecessary delays in completing the work after receiving the NOC.

If a Patrolling Engineer finds that working parties are using machinery on site that wasn't included in the drawings then all work will be stopped. Once the drawings are updated to add the machinery, then the working parties can obtain approval to continue their work.

### H. Stand by site supervision

If the patrolling team assesses the work is being of a medium or high risk for transmission lines, then working parties can ask DEWA for a standby on-site supervisor.

DEWA will assign the supervisor when the working party sends a request as shown on page 31 . The work can only be progressed and completed while the supervisor is present.

Once the working party has implemented all the protective regulations mentioned in the NOC, they will be permitted to continue the work.

## I. Site Photos

Identifying and installing barricades and signs



Vehicle movement restricted near transmission lines



Temporary height limit gantry installation



Material storage area is identified and marked with signage



Tower foundation protected with concrete barrier



Guidance provided to contractors on site



# REQUIREMENTS BEFORE & DURING WORK NEAR TRANSMISSION LINES

## Danger sign board- format

PROPOSED WORK :	TUNNEL / TROUGH / CABLE TYPE : (400/132 kv & F.O.C/PILOT)	
RTA / DEWA NOC NO :	CABLE TYPE : (33/11/6.6 kv & F.O.C/PILOT)	
 <span style="float: right;">هيئة كهرباء ومياه دبي Dubai Electricity &amp; Water Authority</span>		
<b>DANGER HIGH VOLTAGE</b> <b>خطر جهد كهربائي عالي</b>		
		
<b>في الأسفل كابل أرضي 6.6/11/33/132/400 كيلوفولت لهيئة كهرباء ومياه دبي</b> <b>الأنشطة غير المصرح بها ممنوعة</b> <b>DEWA 400/132/33/11/6.6 kv CABLE BELOW</b> <b>Unauthorised Activities Prohibited</b>		
		
ممنوع عمل آليات الحفر فوق أو بالقرب من مسار الكابلات من دون تصريح هيئة كهرباء ومياه دبي <b>No Machine Excavation Over / Near Cable Route Without DEWA NOC</b>	ممنوع رمي النفايات فوق حرم الكابلات <b>No Dumping Above Cable Corridor</b>	ممنوع وقوف المركبات فوق حرم الكابلات <b>No Parking Above Cable Corridor</b>
For further Clarification / Inquiry you may please contact DEWA Engineer:		TLM : (1) ..... (2) ..... DM : (1) 04-3222969 (2) 04-3227410
WORK LIMIT COORDINATES : <input type="checkbox"/> START E- <input type="checkbox"/> END E-		لمزيد من الاستفسارات / الملاحظات يرجى التواصل مع موظف الهيئة
<b>TRANSMISSION LINE MAINTENANCE (TLM)</b>		<b>DISTRIBUTION MAINTENANCE (DM)</b>
TROUGH EDGE COORDINATES : E- ..... N- ..... CLEARANCE FROM TROUGH EDGE TO PROPOSED WORK : ..... m TROUGH DEPTH FROM GROUND LEVEL : ..... m		CLEARANCE FROM CABLE EDGE TO PROPOSED WORK : ..... m CABLE DEPTH FROM GROUND LEVEL : ..... m
TICK APPROPRIATE : <input type="checkbox"/> CROSSING <input type="checkbox"/> ABOVE <input type="checkbox"/> BELOW <input type="checkbox"/> PARALLEL		<input type="button" value="Reset"/> <input type="button" value="Save"/>

## Information:

Please visit website - <https://www.dewa.gov.ae/en/builder/useful-tools/user-manual> for the Infrastructure NOC Technical manual

This manual has the protective regulations required for implementation prior to work being done by the contractor

## What's next?

In the next chapter, you will learn about the patrolling activities of DEWA's Transmission Line Maintenance department.

This will cover the precautionary measures to monitor and permit safe work near lines, like site instructions, issuing stop notices and conducting meetings on site.

# CHAPTER 5

---

## IMPLEMENTATION OF NOC CONDITIONS & PRECAUTIONARY MEASURES

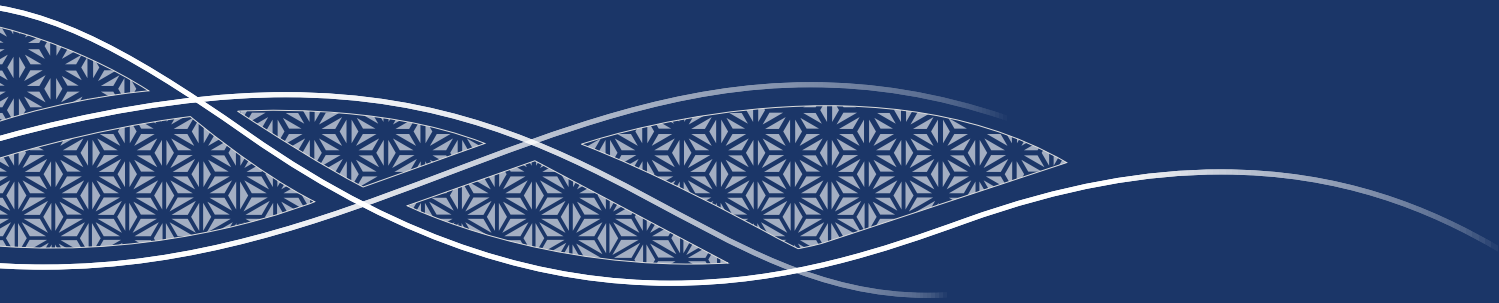

# IMPLEMENTATION OF NOC CONDITIONS & PRECAUTIONARY MEASURES

To ensure implementation of all the provisions of Protective Regulations of this Handbook during execution of any activities near or within the vicinity of the existing OHL and UG Cable Corridors.

---

## 5.1 Patrolling

Patrolling of all existing OHL and cable routes is carried out at a scheduled frequency to monitor DEWA's Transmission lines network from damages and third-party violations by observing, reporting and preventive actions.

### 5.1.1 Routine Patrolling

DEWA's Transmission network and grids are divided into a number of patrolling zones which are patrolled everyday including weekends.

### 5.1.2 Emergency Patrolling

This type of patrolling should be conducted as requested to specific area where damage or tripping has occurred or where transmission facilities need special attention or priority actions to minimise or prevent the possibility of damage.

During emergency visits, DEWA Patrollers will advise the working parties to stop work until further notice to identify the cause.

### 5.1.3 Intensive Patrolling

This type of patrolling is done at the request of the relevant parties, such as DEWA departments, to pay additional attention with extra patrols, to specific circuits to ensure the continued good condition of the remaining cables or lines in the ring network feeder.

### 5.1.4 Special Patrolling

This type of patrolling is done by request from the relevant parties to pay additional attention (extra patrols) to specific circuits.

This is to ensure the good condition of all the transmission lines or cables supplying substations. Examples include substations that power important occasions or VIP visits.

## 5.2 Pre-Commission Inspection

This type of inspection is conducted in response to the request for joint inspection of the completed project. This will ensure that all installed components of the transmission system were installed according to DEWA's standards.

## 5.3 Contractors' Work Supervision

TLM & C directly supervises the execution of all construction activities near or in the vicinity with line or cable corridor to ensure that such work executions are in accordance with the provisions of NOC and Method statement. The following types of supervision should be scheduled as suitable to the kinds of work requirements. (Please refer Annexure-3.1.1 page 31 )

### 5.3.1 Work Supervision Request

All works near or in the vicinity of OHL or UG Cables corridor, if with relevant NOC, should only be executed under direct supervision of TLM & C's Standby Site Supervisor. The service of Standby Site Supervisor will be obtained based on the following requirements:

- A The work intimation request form should be obtained from TLM patrolling/NOC section of DEWA or from Patrolling staff at site. The DEWA work intimation request form is also on the DEWA website. <https://www.dewa.gov.ae/en/builder/useful-tools/forms> Working parties must complete it in full before sending it.

### Submission of completed Forms

- B a. The completed forms should be submitted within two (2) working days, before commencement of the proposed works, to TLM & C - Lines Patrolling section Email: [tlm.supervision@dewa.gov.ae](mailto:tlm.supervision@dewa.gov.ae) .

- b. Alternatively, for priority actions, the contractor should submit the completed form with the required attachment, one day before commencing work, to the office of TLM & C - Lines Patrolling Section.

### 5.3.2 Critical Site Supervision

Any work execution near or in the vicinity of OHL/UG cables corridor, which likely needs special actions to protect the lines by additional guidance and stringent measures. Where coordination with contractors, consultants or government utility departments are required, this may take more time.

### 5.4 Site Instruction Notice

During patrolling, the patroller checks the contractor's worksite and if any non-critical violations are found, then a site instruction notice will be issued to contractors for immediate correction. If contractors don't take the necessary steps, the patroller will issue a notice to stop work (Format attached Figure:5.4) and fines (EVCR).

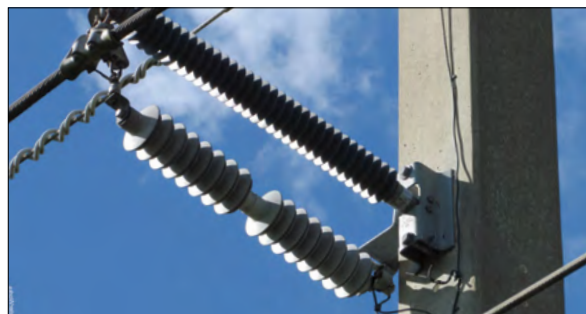







# CHAPTER 6

---

## ACTIONS AGAINST VIOLATORS

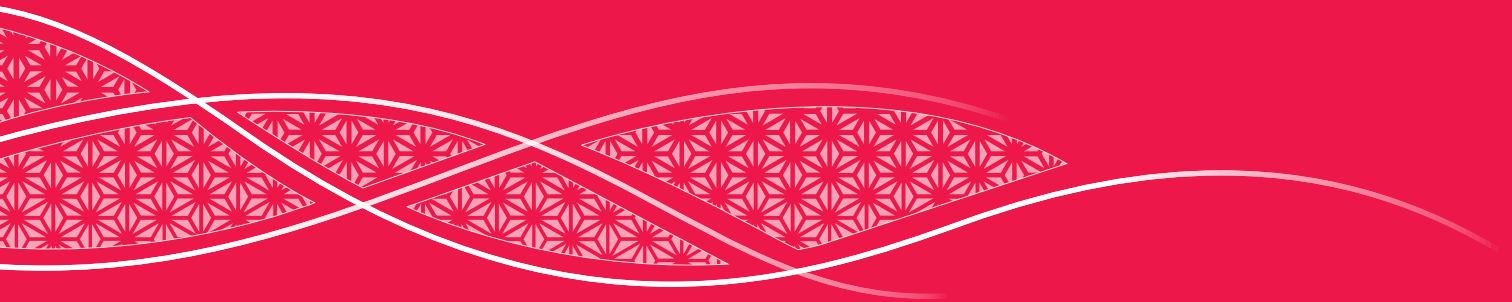

# ACTIONS AGAINST VIOLATORS

## 6.1 Legal Requirements

Legal action and penalty shall be imposed on the violators as per Law no. (6) of 2015. Additionally, Green and Black point system requirements are as per Administrative Resolution 05 of 2022.

SCHEDULE	
VIOLATIONS AND FINES	
SN	Description of Violation
1	Performing any act or conducting any activity near the Public Network without obtaining an Authorisation from DEWA, or with an expired Authorisation
2	Performing, in a breach of the work plan and schedule prescribed by DEWA, any act in any zone which DEWA decides to provide with its services
3	Failure by an Authorisation Holder to comply with the terms of his Authorisation
4	Failure by an Authorisation Holder to keep the Authorisation on the work site
5	Failure by an Authorisation Holder to appoint a specialised Person to supervise the works performed on the work site, or failure of such Person to be available on the site throughout the period of work
6	Commencement by an Authorisation Holder of levelling works or of actual works on the site without notifying DEWA of the work schedule or without observing the required forty-eight (48) hour notice period
7	Failure by an Authorisation Holder to take all necessary actions and measures to protect and maintain the safety of the Public Network in accordance with the relevant standards approved by DEWA
8	Performance by an Authorisation Holder of his works on the site in contrary to the work plan and schedule approved by DEWA
9	Causing damage or compromising the safety of the Public Network
10	Failure to promptly notify DEWA where the works of an Authorisation Holder intersect with the Public Network, or where any damage is caused to the Public Network
11	Failure by a violator to remedy his violation within the grace period prescribed by DEWA
12	Failure to supply a cable detector on the work site
13	Commencing work on the site before conducting the drilling tests prescribed by DEWA
14	Failure to install temporary information signs on the work site indicating cable and water pipeline routes
15	Breach of the obligations prescribed under Article (7) of this Law by owners or occupants of real property located in zones where DEWA decides to provide its services
16	Performing any of the prohibited acts stipulated in Article (8) of this Law
17	Failure to implement a work suspension order issued by DEWA or by any of its competent employees
18	Obstructing the work of DEWA employees or any Person authorised by DEWA to perform inspections
19	Performing any act, other than the violations stated in this Schedule, in breach of the provisions of this Law and the resolutions issued in pursuance hereof

## 6.2 Black Points System

A system Implemented by DEWA as a Preventive measure to monitor and control the contractors, from performing violations of issued NOCs and its conditions at site, which will lead to damage of the DEWA's Transmission lines network.

### Categories and Actions

#### 6.2.1 Action against violators who fall under Category A:

If the contractor performs violations at the site repeatedly and accumulates for example 18 black points (within a period of one year), as per the violations of NOC conditions and protective regulations, the following action shall be taken as mentioned below,

- A1. Contractor works at violated locations will be stopped.
- A2. Inform other Dubai Government authorities and DEWA departments about the Contractor's violation and request measures against them.
- A3. Meeting with clients (DEWA or Private), Contractors & Consultants and list the necessary steps to prevent repeats of these violations.
- A4. Action Plan for safe construction work in close vicinity of 400/132 kV OHL/ Cable should be prepared by

the contractor or consultant, and Dubai Government authorities and DEWA departments and will submit them to TLM & C for review and approval.

- A5. Warning to be issued to Site In charge.

#### 6.2.2 Action against violators who fall under category B:

If accumulation of black points reaches 35 or damage of 400/132kV transmission lines without tripping (within a period of one year), the following action shall be taken as mentioned below,

- B1. All works of the particular project will be stopped.
- B2. All issued NOCs will be suspended for the particular project until fulfilling the requirements specified in B5.
- B3. Inform the utility and DEWA depts. about the Contractor's violation and request for their action against the violated contractor.
- B4. Meeting with clients (DEWA or Private), Contractors & Consultants to list actions to avoid repeating of violations.
- B5. Replace the Project Engineer, Safety Engineer, and Site Supervisor of the project. CV's of the newly appointed staffs will be submitted to TLM & C for review/approval.

## ACTIONS AGAINST VIOLATORS

B6. Action Plan for safe construction work in close vicinity of 400/132 kV OHL/Cable should be prepared by the Contractor/Consultant, and Utility/DEWA Dept. and submit to TLM & C for review/approval to avoid repetition of violation /damage.

### 6.2.3 Action against violators who fall under category C:

If damage of 400/132kV Cable/OHL occurs with tripping and accumulation of black points reaches 48 (within a period of one year), following action shall be taken as mentioned below,

- C1. All works of the particular project will be stopped.
- C2. All issued NOC's will be cancelled for the particular project.
- C3. Stop issuing new NOC's for the period of 3 months to the involved Contractor.
- C4. Inform the utility and DEWA depts. about the Contractor's violation and request for their action against the violated Contractor.
- C5. Meeting with clients (DEWA or Private), Contractors & Consultants to list actions to avoid repeating of violations.
- C6. For resumption of work, either new Contractor/ DEWA approved Contractors to be appointed or

Replace the Project Manager, Project Engineer, Safety Engineer, and Site Supervisor of the project. CVs of the newly appointed staffs will be submitted to TLM & C for review/approval.

C7. Action Plan for safe construction work in close vicinity of 400/132 kV OHL/ Cable should be prepared by the Contractor/Consultant, and Utility/DEWA Dept. and will submit to TLM & C for review/approval. Also New NOC application for the particular project shall be applied through proper channels.

Furthermore works can be resumed, subject to fulfilling above mentioned requirements and agreements as per respective categories.

## 6.3 Green points system

The Green points system has been implemented to reward stakeholders on a regular basis for executing safe works in compliance with DEWA regulations and for exceeding expectations during work execution.

Accordingly, a dedicated Email Id – [tlm.greenpoint@dewa.gov.ae](mailto:tlm.greenpoint@dewa.gov.ae) is provided to the contractor for their initiative to nominate themselves to achieve green points, after fulfilling the requirement mentioned as below

<b>Schedule (2)</b>		
<b>Green Points</b>		
SN	Green Points	Number of Points
1	Satisfying DEWA inspectors and engineers' risk assessment and avoidance requirements in emergencies, such as Covid 19 pandemic	5
2	Completing major projects without receiving any warning from DEWA	5
3	Compliance by the contractor with the standard procedures for protecting assets in the vicinity of the project site, such as deploying security patrols and appointing a safety engineer	4
4	Providing support in repairing breakdowns in emergencies	4
5	Reporting any of DEWA assets that are not shown on the Geographic Information System drawings, outlining their routes, preparing the relevant as-built drawings, and presenting the same to DEWA to update the Geographic Information System	4
6	Providing all necessary documents, as-built drawings, and completion certificates within the time frame, and as per the requirements, prescribed by DEWA	4
7	The Contractor exceeding the standard requirements for protecting the Infrastructure	4
8	Reporting violations and accidents committed by others and affecting DEWA assets	4
9	Submitting proposals on cost-effective alternative working methods in the course of conducting activities related to DEWA assets	3
10	Presenting reports to DEWA engineers on risks and accidents outside the scope of the project	3
11	Proposing creative ideas and alternative practical solutions to protect DEWA assets and services during the implementation of projects	3
12	Complying with the terms of the no-objection certificate issued, and the schedule prescribed, by DEWA in respect of its assets (including those related to the protection, transmission, reduction of levels, and diversions)	2
13	Delivering, in the presence of DEWA representatives, training and awareness workshops on the protection of DEWA assets for workers in the project site	2

## ACTIONS AGAINST VIOLATORS

Privileges will to be granted in respect of Green Points as set out in Schedule (2) attached hereto and subject to the following:

1. The Green Points that entitle an Authorisation Holder to privileges are those exceeding the number of Black Points within a year from the date of recording them.
2. Subject to the provisions of sub-paragraph (b)(1) of this Article, where the number of the Green Points exceeding the Black Points reaches the cumulative limit of fifty (50) Points in a year, the Authorisation Holder will be eligible for receiving a recommendation from the Committee to conclude a settlement in respect of no more than fifty percent (50%) of the fines imposed on him, in accordance with the provisions of the Law and the rules prescribed in the above-mentioned Administrative Resolution No. (4) of 2021.
3. Subject to the provisions of sub-paragraph (b)(2) of this paragraph, where the number of the Green Points exceeding the Black Points is less than the cumulative limit of fifty (50) Points in a year, the Authorisation Holder will be eligible for receiving a recommendation from the Committee, at its discretion, to conclude a settlement in respect of no more than thirty percent (30%) of the fines imposed on him.

# CHAPTER 7

---

SERVICES PROVIDED BY TLM & C

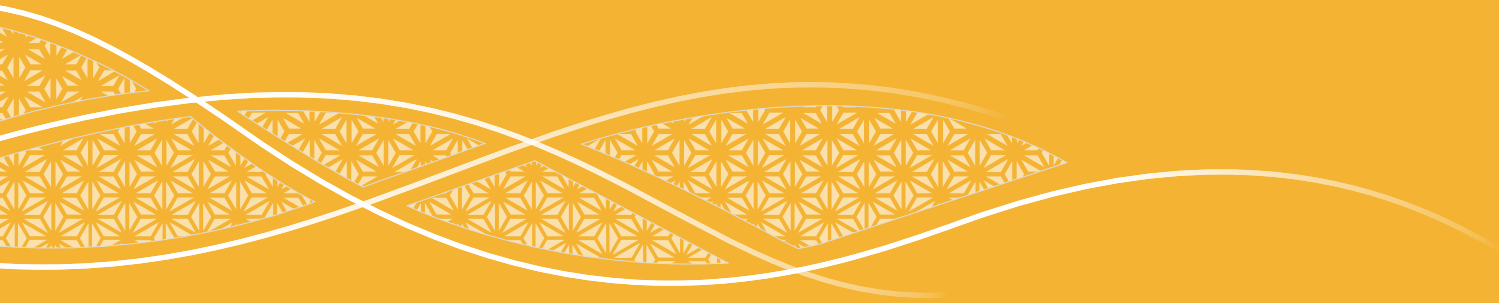

# SERVICES PROVIDED BY TLM & C

## 7.1 Trial pit/OHL Verification & Supervision

To verify the clearance and geographic details of the transmission lines (Cable and OHL) and accessories from the proposed scope of works for NOC applications, Transmission Lines Maintenance & Commissioning - Lines Patrolling section provides the following services to customers, including contractors, consultants and other utilities, in Dubai.

### 7.1.1 Prior Notice, Supervision for trial pit work and verification for the trial pit.

The DEWA work intimation request format should be filled in and sent to DEWA-TLM & C, at least 2 working days in advance by

email to [tlm.supervision@dewa.gov.ae](mailto:tlm.supervision@dewa.gov.ae) with sample attached in page 31.

### 7.1.2 Getting confirmation

Contractors sending an email to request a DEWA Supervisor will get an automatic reply with the Engineer's name and contact details. Contractors can call TLM & C-LP to follow up on 04 322 7929 or 04 322 1547.

### 7.1.3 Work Hours

Works should be carried out during DEWA working hours only. Special approval to be obtained for emergency and very urgent works with justification to work beyond working hours.

## 7.2 Construction Work Supervision

To provide supervisor during the construction activities in the vicinity of 400/132kV Cable/OHL or inside DEWA Corridor.

### 7.2.1 Prior notice, supervision for OHL and cable line protection works

DEWA Work supervision request format duly filled to be sent to DEWA-TLM & C, 02 working days advance by

by email to [tlm.supervision@dewa.gov.ae](mailto:tlm.supervision@dewa.gov.ae) with samples attached in page 31 .

### 7.2.2 Getting confirmation

Contractors sending an email to request a DEWA Supervisor will get an automatic reply with the Engineer's name and contact details. Contractors can call TLM & C-LP to follow up on 04 322 7929 or 04 322 1547.

### 7.2.3 Work Hours

Works should be carried out during DEWA working hours only. Special approval to be obtained for emergency and very urgent works with justification to work beyond working hours. For clarification and follow up in English or Arabic, you can contact us on the following telephone numbers: 04 322 7929 or 04 322 1547 for English, 04 322 1603 for Arabic

#### 7.2.4 Emergency Utility repairs

In case of emergency utility repairs, working parties and contractors should contact our Patrolling Engineers or call 04 322 7929 or 04 322 1547.

The Patrolling Engineer or team will assess the risks to the transmission lines and advise the working party to implement precautionary measures at the site, prior to the repairs.

#### 7.2.5 Awareness/training sessions

Awareness/training sessions are available for contractor's staff to improve and certify their safety skills to work in the vicinity of 400/132kV transmission lines.

In this HandBook, the following items are explained in different chapters, on how to safely execute works & protect existing 400/132kV Transmission Lines network

1. Transmission Lines and Accessories
2. Hazardous factors while working near Transmission Lines
3. NOC's & guidelines on Trial pit/OHL verification

4. Requirements-before and during work near transmission lines
5. Implementation of NOC conditions and precautionary measures
6. Actions against violators.

All of this will help contractors, consultants, utility departments and private parties with their NOC applications, along with the proper method statement and doing safe construction work in and around the transmission lines.

Everyone involved will get general or technical knowledge about the transmission lines and safety precautionary measures to avoid unwanted damage.

All are welcome for queries, clarifications and suggestions if any.

We trust that all contractors, consultants, utility departments and private parties will follow DEWA's protective rules and regulations, and cooperate to achieve Dubai Government's mission to provide uninterrupted electricity supply in Dubai.

## LIST OF ABBREVIATIONS

<b>Approx</b>	Approximate	<b>MM</b>	Millimeter
<b>CS</b>	Connection Services	<b>MTR</b>	meter
<b>DM</b>	Dubai Municipality	<b>NDRC</b>	Non Disruptive Road Crossing
<b>DUSUP</b>	Dubai Supply Authority	<b>NOC</b>	No Objection Certificate
<b>EHV</b>	Extra High Voltage	<b>OHL</b>	Overhead Line
<b>EVCR</b>	Electronic Violation Control Report	<b>OPGW</b>	Optical Ground Wire
<b>EXTG</b>	Existing	<b>RCC</b>	Reinforced Cement Concrete
<b>FO</b>	Fibre Optic	<b>ROW</b>	Right Of Way
<b>FIG</b>	Figure	<b>RTA</b>	Road Transport Authority
<b>FRL</b>	Finished Road Level	<b>TBT</b>	Tool Box Talk
<b>GIS</b>	Geographical Information System	<b>TLM &amp; C - LP</b>	Transmission Lines Maintenance & Commissioning - Lines Patrolling
<b>GPS</b>	Global Positioning System	<b>TL &amp; C</b>	Transmission Lines & Civil Maintenance & Commissioning
<b>HDD</b>	Horizontal Directional Drilling	<b>TP</b>	Trial Pit
<b>II&amp;P</b>	Infrastructure Information & Permits	<b>UG</b>	Underground
<b>kV</b>	Kilo Volt	<b>XLPE</b>	Cross Link Poly Ethylene
<b>M</b>	Meter		

## CONTACT US

For any clarification related to any information mentioned in the Handbook, please send your queries to:

Tel : [04 3227922](tel:043227922)/[04 3221542](tel:043221542)

Email : [t1m.supervision@dewa.gov.ae](mailto:t1m.supervision@dewa.gov.ae)

Website : [www.dewa.gov.ae](http://www.dewa.gov.ae)

